

Solution

Part 1a

$$a. \quad v_{ret} = \sqrt{v_0^2 - 2(e/m)V} = 1.956 \times 10^6 \text{ m/s} \quad (0.5 \text{ pts})$$

$$v_{acc} = \sqrt{v_0^2 + 2(e/m)V} = 2.044 \times 10^6 \text{ m/s}$$

$$x_{ret} = v_{ret}t, \quad x_{acc} = v_{acc}(t - T/2) \quad (0.5 \text{ pts})$$

$$x_{ret} = x_{acc} \rightarrow t_{bunch} = \frac{v_{acc}T}{2(v_{acc} - v_{ret})} = 11.61T \quad (0.3 \text{ pts})$$

$$b = v_{ret}t_{bunch} = 2.272 \times 10^{-2} \text{ m}. \quad (0.2 \text{ pts})$$

b. The phase difference:

$$\Delta\phi = \pm \left(\frac{t_{bunch}}{T} - n \right) 2\pi = \pm 0.61 \times 2\pi = \pm 220^\circ. \quad (1.0 \text{ pts})$$

OR

$$\Delta\phi = \pm 140^\circ$$

Part 1b

$$\rho_L = n_L \frac{M}{N_A} \quad (0.3 \text{ pts})$$

where n_L is the number of molecules per cubic meter in the liquid phase

Average distance between the molecules of water in the liquid phase:

$$d_L = (n_L)^{-1/3} = \left(\frac{M}{\rho_L N_A} \right)^{1/3} \quad (0.2 \text{ pts})$$

$$P_a V = nRT,$$

where n is the number of moles (0.6 pts)

$$P_a = \frac{nM}{V} \frac{RT}{M} = \rho_V \frac{RT}{M} = \frac{n_V M}{N_A} \frac{RT}{M}$$

where n_V is the number of molecules per cubic meter in the vapor phase. (0.9 pts)

$$d_V = (n_V)^{-1/3} = \left(\frac{RT}{P_a N_A} \right)^{1/3} \quad (0.2 \text{ pts})$$

$$\frac{d_V}{d_L} = \left(\frac{RT \rho_L}{P_a M} \right)^{1/3} = 12 \quad (0.3 \text{ pts})$$

Part 1c

a.

(0.5 pts.)

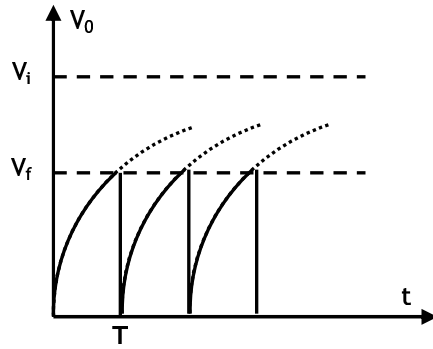

b. $V_i \gg V_f$ (0.2 pts)

c. $V_f = V_i(1 - e^{-T/RC})$

(0.2 pts)

If

$V_i \gg V_f,$

$T/RC \ll 1,$

$e^{-T/RC} \approx 1 - (T/RC)$

then

$T = (V_f / V_i) RC$

(0.2 pts)

d. R

(0.2 pts)

e. SG and R

(0.2 pts)

f. Correct circuit

(0.4 pts)

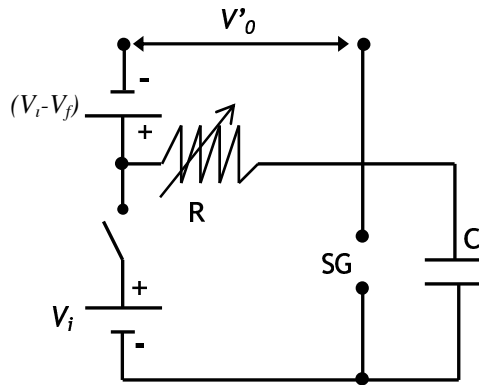

V'_0

(0.3 pts)

$V'_i - V_f$ with the correct polarity

(0.3 pts)

Total

(1.0 pts)

Part 1d

As the beam passes through a hole of diameter D the resulting uncertainty in the y -component of the momentum;

$$\Delta p_y \approx \frac{\hbar}{D} \quad (0.6 \text{ pts})$$

and the corresponding velocity component;

$$\Delta v_y \approx \frac{\hbar}{MD} \quad (0.4 \text{ pts})$$

Diameter of the beam grows larger than the diameter of the hole by an amount

$$\Delta D = \Delta v_y \cdot t,$$

where t is the time of travel.

(0.2 pts)

If the oven temperature is T , a typical atom leaves the hole with kinetic energy

$$KE = \frac{1}{2} Mv^2 = \frac{3}{2} kT \quad (0.4 \text{ pts})$$

$$v = \sqrt{\frac{3kT}{M}} \quad (0.2 \text{ pts})$$

Beam travels the horizontal distance L at speed v in time

$$t = \frac{L}{v}, \text{ so} \quad (0.2 \text{ pts})$$

$$\Delta D = t \Delta v_y \approx \frac{L}{v} \frac{\hbar}{MD} = \frac{L\hbar}{MD\sqrt{\frac{3kT}{M}}} = \frac{L\hbar}{D\sqrt{3MkT}} \quad (0.4 \text{ pts})$$

Hence the new diameter after a distance L will be;

$$D_{\text{new}} = D + \frac{L\hbar}{D\sqrt{3MkT}} \quad (0.1 \text{ pts})$$