

Figure 1.2: A hexagonal prism lying on an inclined plane.

- b) (1 point) The kinetic energy of the prism just before and after impact is similarly K_i and K_f .

Show that we may write

$$K_f = rK_i \quad (1.4)$$

and write the value of the coefficient r on the answer sheet.

- c) (1.5 points) For the next impact to occur K_i must exceed a minimum value $K_{i,min}$ which may be written in the form

$$K_{i,min} = \delta Mga \quad (1.5)$$

where $g = 9.81 \text{ m/s}^2$ is the acceleration of gravity.

Find the coefficient δ in terms of the slope angle θ and the coefficient r . Write your answer on the answer sheet. (Use the algebraic symbol r , not its value).

- d) (2 points) If the condition of part (c) is satisfied, the kinetic energy K_i will approach a fixed value $K_{i,0}$ as the prism rolls down the incline.

Given that the limit exists, show that $K_{i,0}$ may be written as:

$$K_{i,0} = \kappa Mga \quad (1.6)$$

and write the coefficient κ in terms of θ and r on the answer sheet.

- e) (2 points) Calculate, to within 0.1° , the minimum slope angle θ_0 , for which the uneven rolling, once started, will continue indefinitely. Write your numerical answer on the answer sheet.

1.2 Solution

a)

Solution Method 1

At the impact the prism starts rotating about a new axis, i.e. the edge which just hit the plane. The force from the plane has no torque about this axis, so that the angular momentum about the edge is conserved during the brief interval of impact. The linear

momentum of the prism as a whole has the same direction as the velocity of the center of mass ($\vec{P} = M \vec{v}_C$ where the subscript C refers to the center of mass), and this direction is easy to follow when we know the axis of rotation at a given time. Just before impact \vec{P} is directed 30° downwards relative to the plane, but will after impact point 30° upwards from the plane, see Figure 1.3.

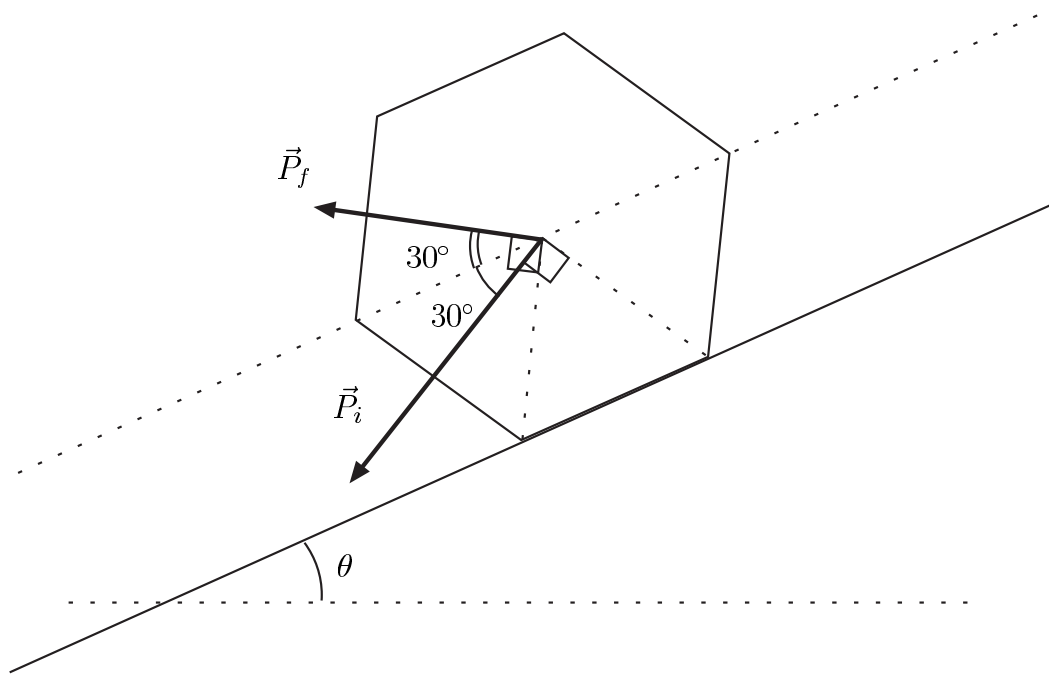

Figure 1.3: *The linear momentum of the prism as a whole, before and after impact.*

To find the angular momentum about the edge of impact just before the impact we use the equation relating angular momentum \vec{L} about an arbitrary axis to the angular momentum \vec{L}_C about an axis through the center of mass parallel to the first one:

$$\vec{L} = \vec{L}_C + M \vec{r}_C \times \vec{v}_C \quad (1.7)$$

where the subscript C refers to the center of mass. Here, this is applied to an axis at the point of impact so that \vec{r}_C is the vector from that point to the center of mass (Figure 1.3). The vectors on the right hand side of equation (1.7) both have the same direction. Hence we get for the quantities just before impact²

$$|\vec{r}_C \times \vec{v}_{Ci}| = r_C v_{Ci} \sin 30^\circ = a^2 \omega_i / 2 \quad (1.8)$$

$$L_i = I \omega_i + \frac{1}{2} M a^2 \omega_i = \left(\frac{5}{12} + \frac{1}{2} \right) M a^2 \omega_i = \frac{11}{12} M a^2 \omega_i \quad (1.9)$$

On the other hand, angular momentum about the edge just after impact is, from equation (1.2):³

²This may also be done by using Steiner's theorem twice, going from the previous axis of impact to the center of mass and from there to the new axis of impact.

³Alternatively:

$$L_f = I' \omega_f = \frac{17}{12} M a^2 \omega_f \quad (1.10)$$

where the subscript f always refers to the situation just after impact. We may notice that the difference comes about because of the different directions of \vec{v}_{C_i} and \vec{v}_{C_f} . Now, when we state the conservation of angular momentum, $L_i = L_f$, we obtain a relation between the angular velocities as follows:

$$\omega_f = \frac{11/12}{17/12} \omega_i = \frac{11}{17} \omega_i \quad (1.11)$$

We thus get:

$$\mathbf{s} = \mathbf{11/17} \quad (1.12)$$

We may note that s is independent of a , ω_i , and θ .

Solution Method 2

On impact the prism receives an impulse \vec{P} [N · s] from the plane at the edge where the impact occurs. There is no reaction at the edge which is leaving the plane. The impulse has a component P_{\parallel} parallel to the inclined plane (positive upwards along the incline in Figure 1.3 and a component P_{\perp} perpendicular to the plane (positive upwards from the plane in the same figure).

We can set up three equations with the three unknowns P_{\parallel} , P_{\perp} and the ratio $s = \frac{\omega_f}{\omega_i}$. The quantity P_{\parallel} is the change in the parallel component of the linear momentum of the prism and P_{\perp} is the corresponding change in perpendicular linear momentum. Thus:

$$P_{\parallel} = M (\omega_i - \omega_f) a \cdot \frac{\sqrt{3}}{2} \quad (1.13)$$

$$P_{\perp} = M (\omega_i + \omega_f) a \cdot \frac{1}{2}. \quad (1.14)$$

We finally have:

$$P_{\perp} a \frac{1}{2} - P_{\parallel} a \frac{\sqrt{3}}{2} = I (\omega_i - \omega_f) \quad (1.15)$$

since the right hand side is the change in angular momentum about the center of mass. Equations (1.13), (1.14) and (1.15) can now be solved for the ratio $s = \frac{\omega_f}{\omega_i}$ giving, of course, the same result as before.

$$\begin{aligned} L_f &= I \omega_f + M |\vec{r}_C \times \vec{v}_{C_f}| = I \omega_f + M a^2 \omega_f \sin 90^\circ \\ &= \left(\frac{5}{12} + 1 \right) M a^2 \omega_f = \frac{17}{12} M a^2 \omega_f \end{aligned}$$

b)

The linear speed of the center of mass just before impact is $a\omega_i$ and just after impact it is $a\omega_f$. We know that we can always write the kinetic energy of a rotating rigid body as a sum of „internal“ and „external“ kinetic energy:

$$K_{tot} = \frac{1}{2} I \omega^2 + \frac{1}{2} M v_C^2 \quad (1.16)$$

From this we see that in our case the kinetic energy K_{tot} is proportional to ω^2 both before and after impact so that we get

$$K_f = r K_i = \left(\frac{11}{17}\right)^2 K_i = \frac{121}{289} K_i \quad (1.17)$$

so

$$r = 121/289 \approx 0.419 \quad (1.18)$$

c)

The kinetic energy K_f after the impact must be sufficient to lift the center of mass to its highest position, straight above the point of contact. The angle through which \vec{r}_C moves for this is

$$x = \frac{\alpha}{2} - \theta \quad (1.19)$$

where $\alpha = 60^\circ$ is the top angle of the triangles meeting at the center of the polygon.⁴ The energy for this lifting of the center of mass is

$$E_0 = Mga(1 - \cos x) = Mga(1 - \cos(30^\circ - \theta)) \quad (1.20)$$

and we get the condition

$$K_f = rK_i > E_0 = Mga(1 - \cos(30^\circ - \theta)) \quad (1.21)$$

thus

$$\delta = \frac{1}{r} (1 - \cos(30^\circ - \theta)) \quad (1.22)$$

(Note that $\cos(30^\circ - \theta) = \frac{\sqrt{3}}{2} \cos \theta + \frac{1}{2} \sin \theta$).

d)

Let $K_{i,n}$ and $K_{f,n}$ be the kinetic energies just before and just after the n th impact. We have shown that we have the relation

⁴In the general case $\alpha = 2\pi/N$.

$$K_{f,n} = r K_{i,n} \quad (1.23)$$

where $r = \frac{121}{289}$ for a hexagonal prism. Between subsequent impacts the height of the center of mass of the prism decreases by $a \sin \theta$ and its kinetic energy increases for this reason by

$$\Delta = Mga \sin \theta \quad (1.24)$$

We therefore have

$$K_{i,n+1} = rK_{i,n} + \Delta. \quad (1.25)$$

One does not have to write out the complete expression $K_{i,n}$ as a function of $K_{i,1}$ and n to find the limit. This would actually be a proof that the limit exists (see below) but this is given in the problem text. Hence one can make $K_{i,n+1} \approx K_{i,n}$ arbitrarily accurate for sufficiently large n . The limit $K_{i,0}$ must thus satisfy the iterative formula, i.e.

$$K_{i,0} = rK_{i,0} + \Delta \quad (1.26)$$

yielding the solution

$$K_{i,0} = \frac{\Delta}{1-r}. \quad (1.27)$$

i.e.

$$\kappa = \frac{\sin \theta}{1-r} \quad (1.28)$$

We can also solve the problem explicitly by writing out the full expressions:

$$K_{i,2} = r K_{i,1} + \Delta \quad (1.29)$$

$$K_{i,3} = r K_{i,2} + \Delta = r^2 K_{i,1} + (1+r)\Delta \quad (1.30)$$

...

$$K_{i,n} = r^{n-1} K_{i,1} + (1+r+\dots+r^{n-2})\Delta \quad (1.31)$$

$$= r^{n-1} K_{i,1} + \frac{1-r^{n-1}}{1-r}\Delta \quad (1.32)$$

In the limit of $n \rightarrow \infty$ we get

$$K_{i,n} \rightarrow K_{i,0} = \frac{\Delta}{1-r} \quad (1.33)$$

which is, of course, the same result as before.

If we calculate the change in kinetic energy through a whole cycle, i.e. from just before impact number n until just before impact $n+1$ we get

$$\Delta K_{i,n} = K_{i,n+1} - K_{i,n} = (r-1)r^{n-1}K_{i,1} + r^{n-1}\Delta \quad (1.34)$$

$$= r^{n-1}(\Delta - (1-r)K_{i,1}) \quad (1.35)$$

This is positive if the initial value $K_{i,1} < K_{i,0}$ so that $K_{i,n}$ will then increase up to the limit value $K_{i,0}$. If, on the other hand, $K_{i,1} > K_{i,0}$, the kinetic energy $K_{i,n}$ just before impact will decrease down to the limit $K_{i,0}$.

All of this may remind you of motion with friction which increases with speed. Mathematically speaking, the main difference is that we here are dealing with difference equations instead of differential equations.

e)

For indefinite continuation the limit value of K_i in part (d) must be larger than the minimum value for continuation found in part (c):

$$\frac{1}{1-r}\Delta = \frac{1}{1-r}Mga \sin \theta > Mga (1 - \cos(30^\circ - \theta)) / r \quad (1.36)$$

We put $A = \frac{r}{1-r} = \frac{121}{168}$:

$$A \sin \theta > 1 - \cos 30^\circ \cos \theta - \sin 30^\circ \sin \theta \quad (1.37)$$

$$(A + 1/2) \sin \theta + \sqrt{3}/2 \cos \theta > 1 \quad (1.38)$$

To solve this we define⁵

$$u = \arccos \left(\frac{A + 1/2}{\sqrt{(A + 1/2)^2 + 3/4}} \right) \approx 35.36^\circ \quad (1.39)$$

and obtain

$$\cos u \sin \theta + \sin u \cos \theta > 1/\sqrt{(A + 1/2)^2 + 3/4} \quad (1.40)$$

$$\sin(u + \theta) > 1/\sqrt{(A + 1/2)^2 + 3/4} \quad (1.41)$$

$$\theta > \arcsin\{1/\sqrt{(A + 1/2)^2 + 3/4}\} - u \approx 41.94^\circ - 35.36^\circ = 6.58^\circ \quad (1.42)$$

That is

$$\theta_0 \approx 6.58^\circ \quad (1.43)$$

If $\theta > \theta_0$ and the kinetic energy before the first impact is sufficient according to part (c), we will, under the assumptions made, get an indefinite “rolling”.

⁵You can of course solve any of the inequalities in a purely numerical way, e.g. by progressive guessing or by using the approximations $\sin \phi \approx \phi$ and $\cos \phi \approx 1 - \phi^2/2$.

1.3 Grading scheme

Part 2(a)	
Answer: $s = \omega_f/\omega_i = 11/17$, equation (1.12)	3.5
Part 2(b)	
Answer: $r = K_f/K_i = s^2 = 121/289$, equation (1.18)	1.0
Part 2(c)	
Answer: $K_{i,min}$ by δ , equation (1.22)	1.5
Part 2(d)	
Answer: Limit $K_{i,0}$ by $\kappa = \sin \theta/(1 - r)$, equation (1.28)	2.0
Part 2(e)	
Answer: Minimum angle $\theta_0 = 6.58^\circ$, equation (1.43)	2.0